

Hand chain hoist model VS///

Capacity 250 - 5000 kg

The newly designed hand chain hoist VS/// is an innovative further development introduced by Yale. The improved hand chain guide prevents canting or jamming of the hand chain, leading to a smooth running of the chain. High quality bearings on side plates, gearbox and load chain sheave ensure smooth operation of load chain and drive pinion.

Optimized hand forces set standards for easy operation.

Features

- Strong bolts between side plates and housing cover and the reinforced hand wheel cover ensure increased stability.
- Precision machined guide rollers ensure smooth running of the load chain.
- High quality bearings for gearbox, side plates and load chain sheave permit a long service life.
- Zinc-plated and yellow-chromated brake parts and guide rollers ensure increased corrosion protection.
- Zinc-plated load chain as standard for added corrosion protection.

Options

- Overload protection device
- Chain container



Load chain sheave with needle bearing



Housing cover with ball bearing

Technical data model VSIII

Model	EAN-No. 4025092*	Capacity in kg/ number of chain falls	Chain dimensions d x p mm	Lift per 1m hand chain overhaul mm	Handle pull at WLL daN	Weight at standard lift (3m) kg
VSIII 0,25/1	*665322	250/1	4x12	50	20	3.9
VSIII 0,5/1	*949545	500/1	5x15	26	21	9.0
VSIII 1,0/1	*949927	1000/1	6x18	24	24	11.5
VSIII 1,5/1	*593854	1500/1	8x24	17	30	17.5
VSIII 2,0/1	*949934	2000/1	8x24	19	32	19.0
VSIII 2,0/2	*949941	2000/2	6x18	15	29	17.3
VSIII 3,0/1	*949958	3000/1	10x30	12	40	31.0
VSIII 3,0/2	*949965	3000/2	8x24	10	37	27.0
VSIII 5,0/2	*949972	5000/2	10x30	8	41	43.0

Dimensions model VSIII

Model	VSIII 0,25/1	VSIII 0,5/1	VSIII 1,0/1	VSIII 1,5/1	VSIII 2,0/1	VSIII 2,0/2	VSIII 3,0/1	VSIII 3,0/2	VSIII 5,0/2
A min., mm		350	380	450	460	490	570	580	700
B, mm		21	27	33	37	37	46	46	56
C, mm	26	28		37		41	44	44	50
D, mm	11		19		27	27		31	37
E, mm		145		180	205	170		220	250
F, mm	113		155		180	155	210		190
G, mm	65	80		85	94	87	110	94	95
H, mm		60	68	90		68	100	81	95
K, mm	190		270		321		370		410

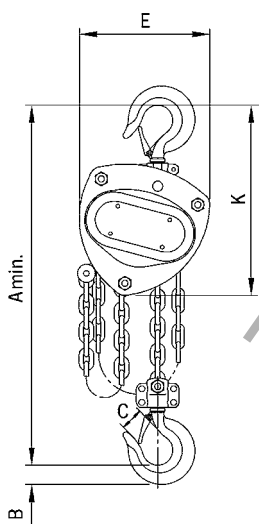

Model VSIII, 250 - 3000kg, single fall

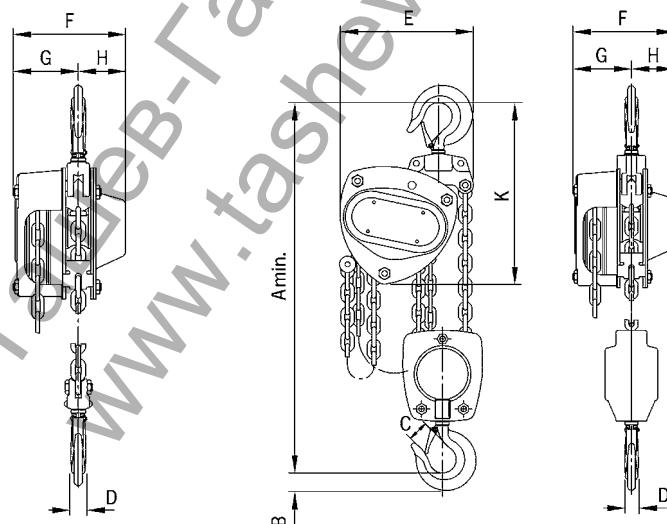

Model VSIII, 2000 - 5000kg, double fall



Option: Chain container

INFO

Yale hoists and trolleys are not designed for passenger elevation applications and must not be used for this